

# GOLDENSEA UM

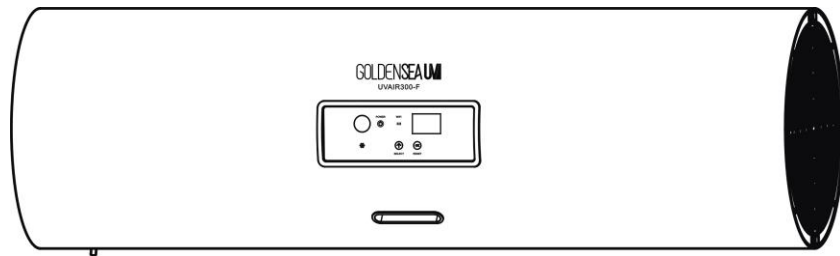

UVAIR300-F

## USER MANUAL

KEEP THIS MANUAL FOR FUTURE NEEDS



Thank you for purchasing a GOLDENSEA UV product. You have acquired a powerful and versatile product. We are confident that you will be satisfied with our excellent product and service. For your own safety, please read this user manual carefully before operating the product.

## **Contents**

<b>1. Product Overview</b>	<b>3</b>
<b>2. Display Panel Overview</b>	<b>3</b>
<b>3. Using The Product</b>	<b>4</b>
<b>4. Dimensional Drawings</b>	<b>7</b>
<b>5. Installation Instructions</b>	<b>7</b>
<b>6. Replacing and Cleaning the Filters</b>	<b>8</b>
<b>7. Replacing The UV Tubes</b>	<b>10</b>
<b>8. Troubleshooting Tips</b>	<b>11</b>
<b>9. Features</b>	<b>12</b>
<b>10. Cleaning and Maintenance</b>	<b>12</b>
<b>11. Recycling</b>	<b>13</b>
<b>12. Service</b>	<b>13</b>

**Voltage Input:** AC110-120V~,50/60Hz; AC220-240V~,50/60Hz; **Power:** 500W;  
**Product Size:** 1262xØ380mm

This product is for commercial use with fixed installation, such as in waiting rooms, classrooms, office, workshop, hotel, theaters, conference rooms, restaurants and other public places etc.

### **IMPORTANT!**

When using electrical equipment, basic safety precautions should always be followed. READ AND FOLLOW ALL SAFETY INSTRUCTIONS carefully before using this product, save it for future reference.

- Check and make sure the voltage indicated on this product corresponds to the local power voltage before connecting this product to the power socket.
- Do not use this product if the plug, power cable, or the product itself is damaged. If anything damaged, it must be replaced or repaired before using, to avoid a hazard.
- Do not use the product in wet surroundings or in surroundings with high ambient temperatures, or near gas products, heating devices or fireplaces.
- Do not use the product in a room with major temperature changes, as this may cause condensation inside the product.
- Do not block the air inlet and outlet by placing any items on the air inlet and outlet.
- Do not use this product for other than intended use.
- Make sure that foreign objects do not fall into the product through the air outlet.
- Do not let water, other liquid or flammable detergent enter this product, to avoid risk of electric shock or fire hazard.
- Do not sit or stand on the product. Sitting or standing on the product may lead to potential damage or injury.
- Do not clean this product with water, other liquid, or flammable detergent, to avoid risk of electric shock or fire hazard.
- Always attach a safety cable to the product when it is installed by hanging on wall or ceiling, to avoid falling by accident.
- Always unplug the product after use and before cleaning, or carrying out other maintenance or replacing any accessory.
- Only use the original accessory specially intended for this product. Do not use any other accessory. The use of accessory not recommended by the manufacturer may cause an unsafe condition.

## 1. Product Overview

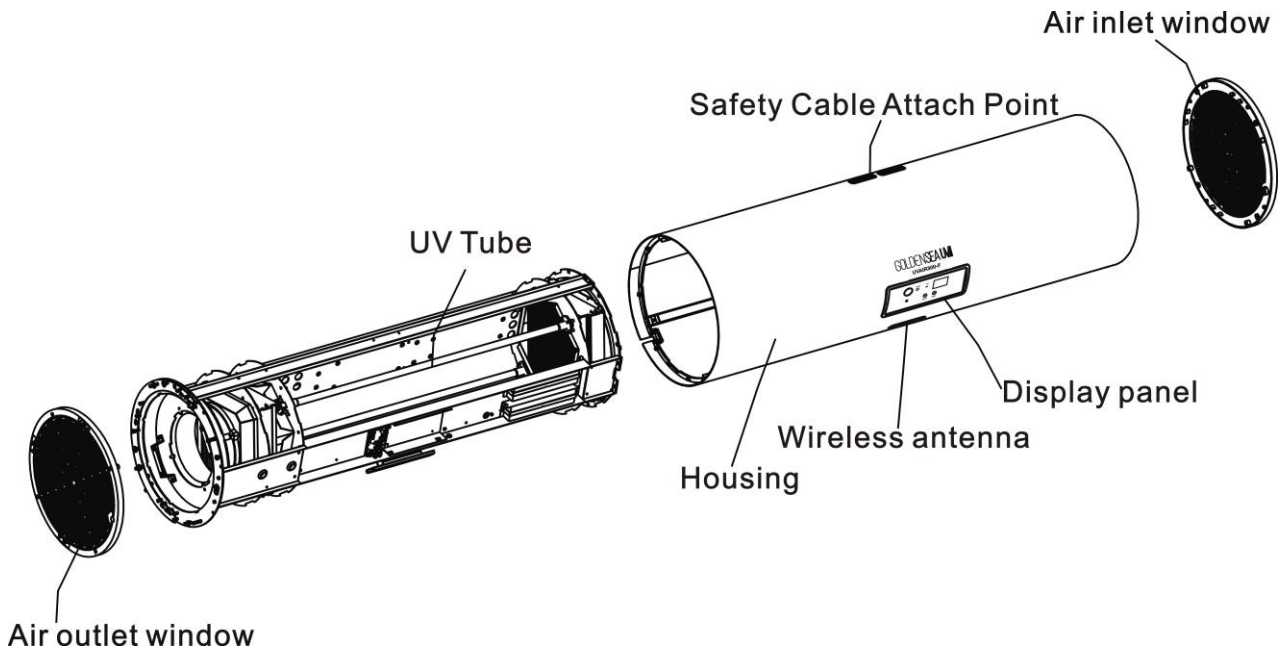

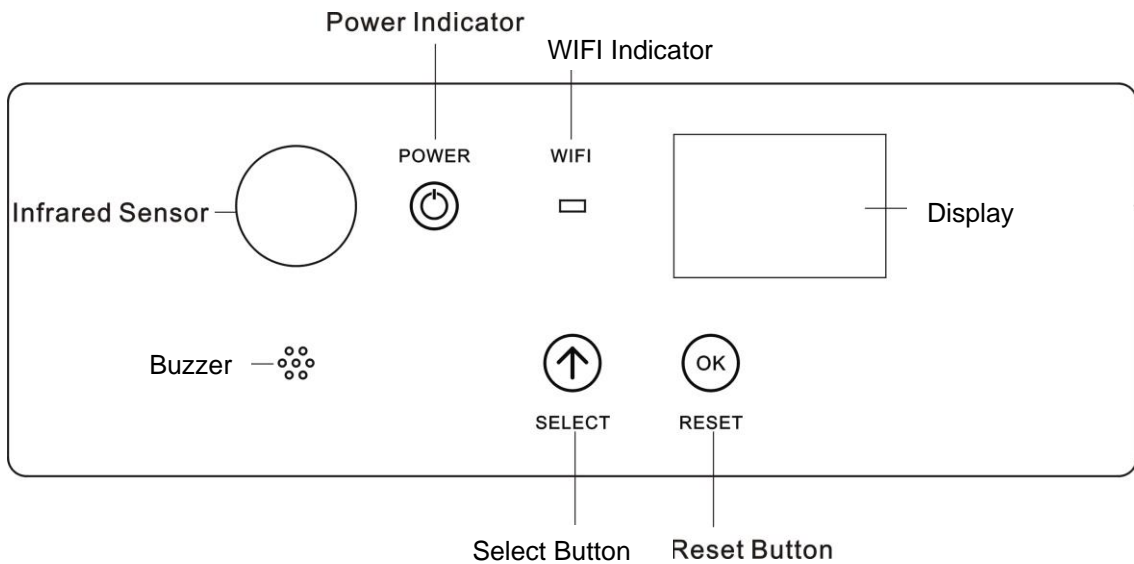

## 2. Display Panel Overview



### Touch Buttons:

	Touch to Select the reset menu(code) in display
	Touch to Reset
	Pressing two buttons for 3 seconds to display WIFI info

**Indicators:**

<p>POWER</p> 	<p>Power indicator(green) Solid: operating</p>
<p>WIFI</p> 	<p>WIFI indicator(blue) Quick flash 3 times regularly: invalid activation code Quick flash 2 times regularly: connecting APP Slow flash (on and off) continuously: connecting WIFI network Solid: WIFI connected; Off: WIFI disconnected</p>
<p>All Indicators Off (when power on)</p>	<p>Indicators turned off from APP</p>

**Display Codes:**

LC	Lamps lifespan alert: Lamps need to be replaced
PC	Pre-filter lifespan alert: filter needs to be replaced
CC	Active carbon filter lifespan alert: filter needs to be replaced
F1 - F4	4 Fan Speeds: F1(Silent), F2(Low), F3(Mid), F4(Max)
88	Flashing: device selected from APP

**3. Using The Product**

**3.1 Before Use**

In the package, you will find the following:

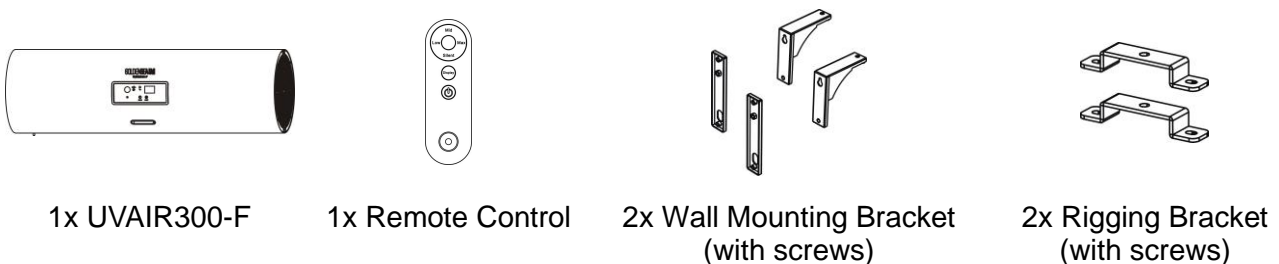



- For best purification and disinfection performance, close all the doors and windows.
- Keep curtains, clothes, papers, etc... away from the air inlet or outlet.

This product is designed with UV lamps inside, the UVC can do high efficient disinfection to the air which going through this product during the air purification process.

High volume air change, up to 1200 cubic meters per hour.

### 3.2 Operation

#### Remote Control Operation:

1. Connect the power plug of the product to the power socket.
2. Press the button  to start the operation.
3. Press the button < Silent >, < Low >, < Mid > or < Max > to select your desired fan speed, the display will indicate the corresponding code F1, F2, F3 or F4.
4. Press the button  to stop the operation.

- \* The button < Display > can turn off the LED and display on product.
- \* Battery type for the remote control: CR2025.

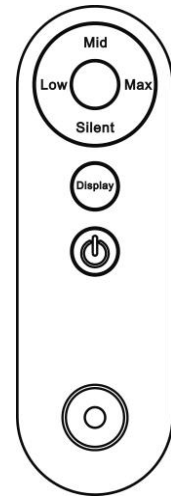

#### WIFI APP Operation

- Connect your mobile phone to the LAN network.
- Make sure the LAN network you connected is 2.4G WIFI, not 5G WIFI.
- One LAN network is only for one user to bind device, not for multi-user.

Download "GOLDENSEA UV" APP from App store or Android market and install into your mobile phone.

Steps to Connect your device to the LAN network and Bind:

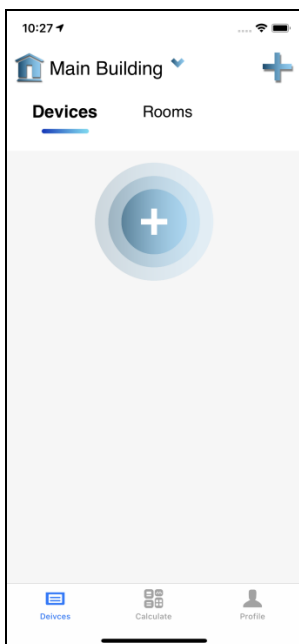

1. Launch the APP, click “ + ” to select and add new device.

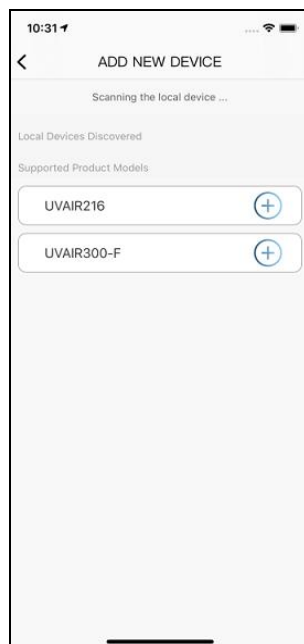

2. Click the device in the list which you want to connect.

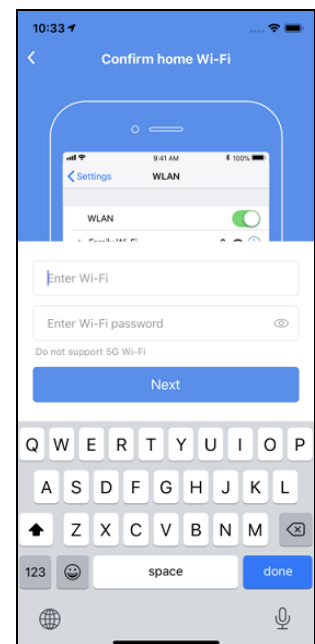

3. Input the WIFI name and password, click “Next” to connect.

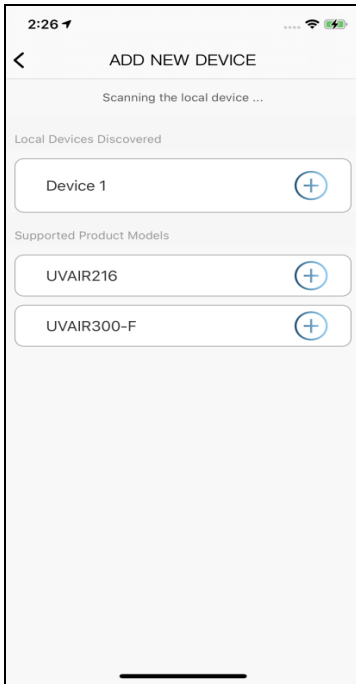

4. Select the device from the list of "Local Devices Discovered".

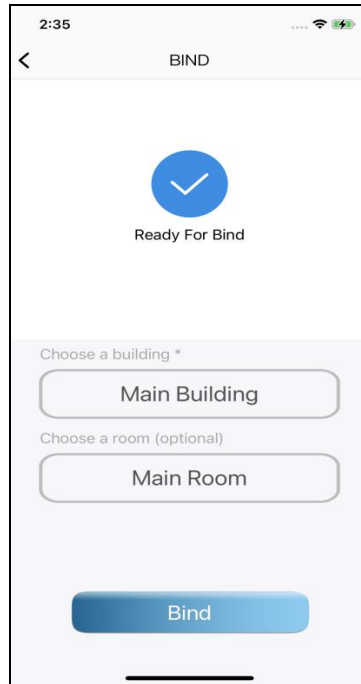

5. Choose "Main Building" and click "Bind". (you can also choose "Main Room" as an option)



6. You can find the device(s) in the "Main Building" and "Rooms".

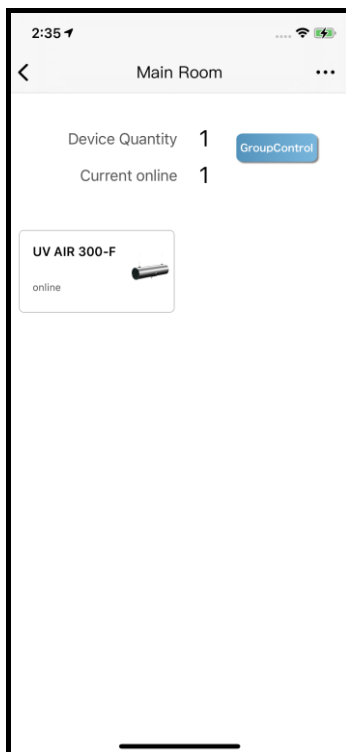

7. Now you can control the device from the APP.

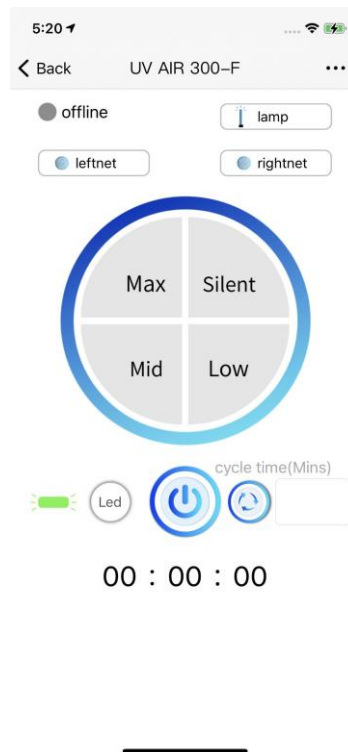

## 4. Dimensional Drawings

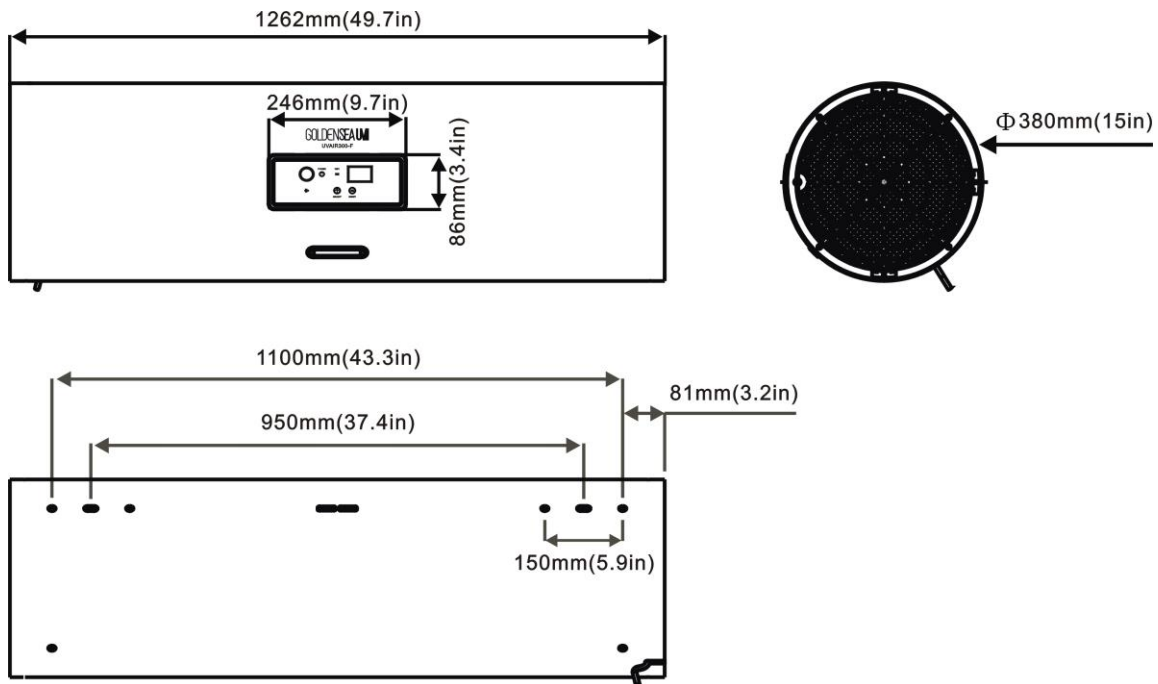

## 5. Installation Instructions

### 5.1 Wall Mounting

1. Fix the triangular Brackets to the screw holes on the product using the 4 screws (M10x30mm) provided.
2. Mount the 2 flat Brackets on the wall with a distance of 1020mm using the 4 screws (M8x50mm) provided.
3. Hang the product (using the 2 hooks of the triangular Brackets) onto the 2 screw heads of the flat Brackets.
4. Important: always attach a safety cable (not included) between the attach point on the product and the wall, to prevent the product from falling off by accident or misuse).

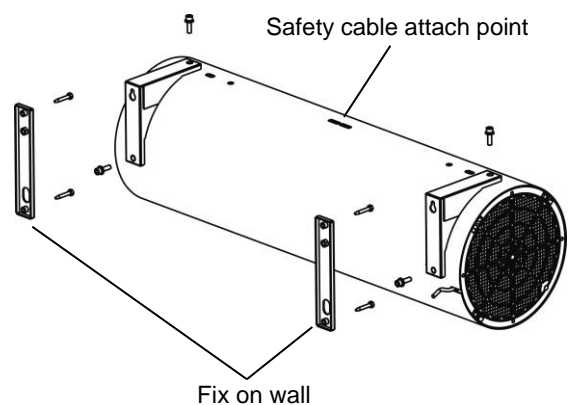



## 5.2 Rigging

1. Fix the rigging brackets to the rigging holes on top of the product with 4 screws (M10x22mm) provided.
2. Fix your hanging rods (not included) to the rigging brackets as shown.
3. Important: always attach a safety cable (not included) between the attach point on the product and the ceiling, to prevent the product from falling off by accident or misuse).

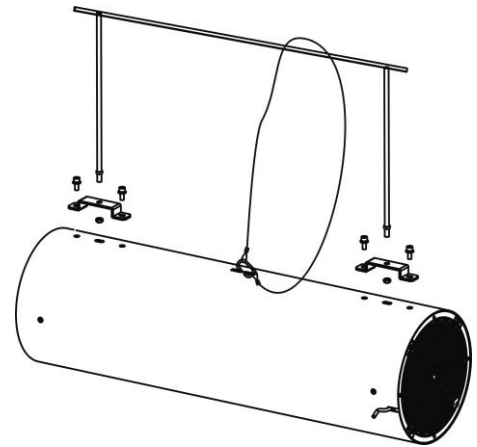

## 6. Replacing and Cleaning the Filters

- Always turn off the product and unplug from the socket before replacing the filters.
- The Active Carbon Filters are not washable or reusable.
- Before carrying out any replacement and cleaning, wait about 15 minutes after switching off the product (to let the UV tubes cool down to avoid scalding).

### 6.1. Cleaning or replacing the Pre-filter

The Pre-filter need to be checked and cleaned regularly to avoid dust accumulated and wind flow efficiency reduced. When the Pre-filter needs to be cleaned or changed, the display will indicate code “PC” and stay flashing.

- Do not clean the Pre-filters with a vacuum.
- If the pre-filter is damaged, worn or broken, do not use.

#### Steps:



1. Loosen the 4 screws with a screwdriver.

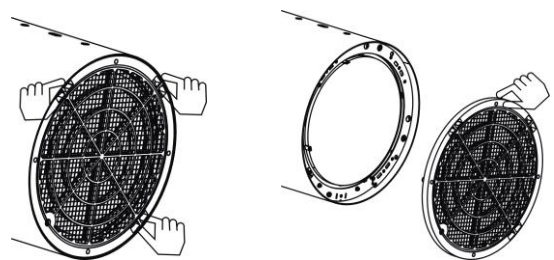

2. Pull the filter assembly out from the holder.

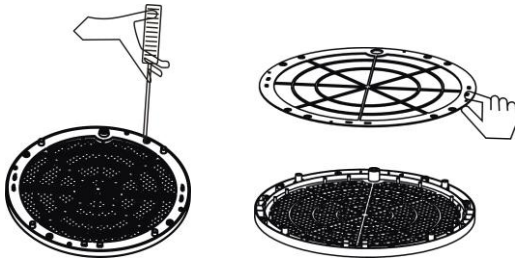

3. Remove the 16 screws and take the filter out.

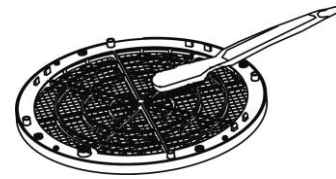

4. Clean the filter with brush (or change with new one), then install it back to the product.

The product is now ready for use again.

\* After filter replacement, remember to reset the filter hours in the display menu: select the code "PC" in display and press reset button.

## 6.2. Replacing the Active Carbon Filter

This product is equipped with an active carbon filter replacement indicator to make sure that the air purification filter is in optimal condition when operating. When the filter needs to be replaced, the display will indicate code "CC" and stay flashing. Replace the filter as soon as possible.

### Steps:



1. Loosen the 4 screws with a screwdriver.

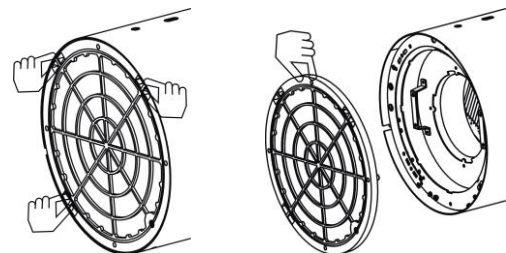

2. Pull the filter assembly out from the holder.

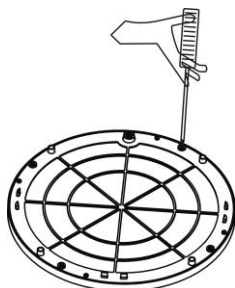

3. Remove the 16 screws and take the filter out.

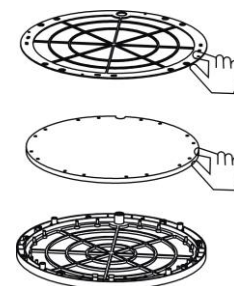

4. Install a new active carbon filter, then install the filter assembly back to the product.

The product is now ready for use again.

\* After filter replacement, remember to reset the filter hours in the display menu: select the code "CC" in display and press reset button.

## 7. Replacing The UV Tubes

To maintain the sterilizing efficacy, the UV tube needs to be replaced after 9,000 hours of use, and the display will indicate code "LC" and stay flashing.

If the lamps are not replaced in time, the product will stop operating and automatically lock to protect the disinfection effect in the room. Replace the lamps as soon as possible.

- Before carrying out any replacement, wait about 15 minutes after switching off the product (to let the UV tubes cool down to avoid scalding).

### Steps:

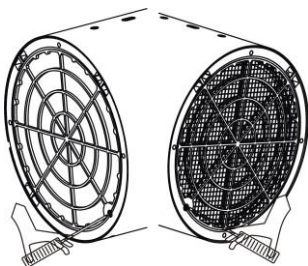

1. Loosen the 4 screws on both sides with a screwdriver.

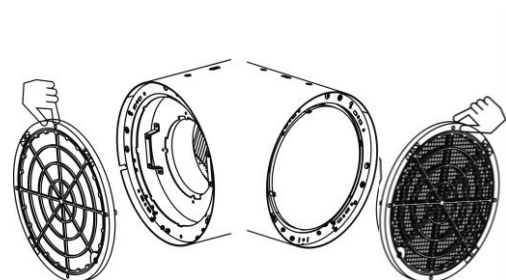

2. Remove the pre-filter assembly and active carbon filter assembly on both sides.

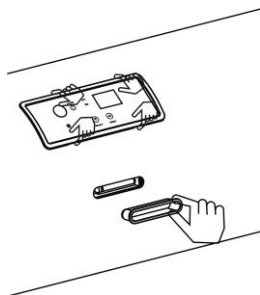

3. Remove the display panel and wireless antenna panel by pulling it out. If it is too tight, use a tool to loosen a little first.

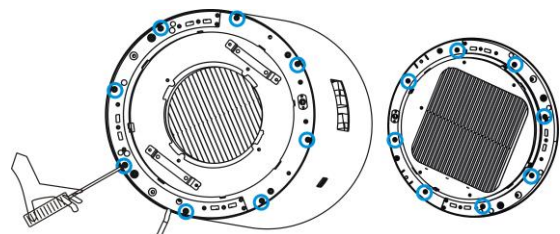

4. Remove the 8 screws on both sides with a screwdriver.

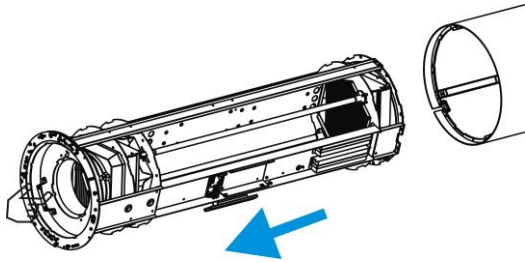

5. Pull the whole UV tubes assembly out from the housing.

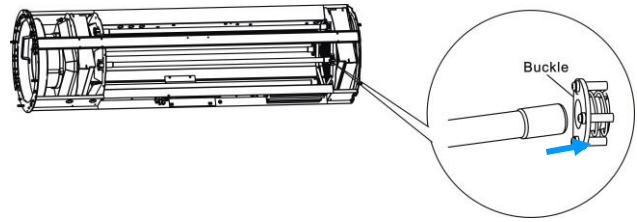

6. Press the spring buckle towards right side and release the right end of UV tube, holding it and pull the left end of the UV tube out of it holder towards the right side.  
Install a new UV tube.

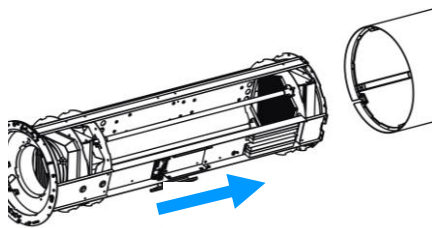

7. Install the whole UV tubes assembly back to the housing. Then fix and install other parts back step by step.

The product is now ready for use again.

\* After lamps replacement, remember to reset the lambs hours in the display menu: select the code "LC" in display and press reset button.

\* Note: please follow your local toxic and hazardous waste regulations for lamp disposal.

## 8. Troubleshooting Tips

### 8.1 What to do if the product doesn't work?

1. Ensure the product is connected into a working socket, plug is wired correctly and terminal well-connected.
2. Check if the remote control is defected or if it is running out of battery.

### 8.2 How often should the UV tube be replaced?

1. The UV tube is the core of the product, it should be replaced after 9000 hours of use to maintain the germicidal efficacy. The display will indicate code "LC" once it needs to be replaced.
2. If the UV tube is defected or damaged, please contact your local dealer or our customer service to order a new UV tube. For replacing the UV tube, please refer to the instructions in this user manual.

3. After use for a period of time, it is normal to find some black spots on both sides of the UV tube.

### **8.3 Why airflow coming out from the air outlet is significantly weaker than before?**

1. Check if the pre-filter is dirty, if so, clean the pre-filter.

### **8.4 Why the display indicator for replacement of filters or lamps still turn on even after they have just been replaced?**

1. Check if you have reset the filter or the lamp hours on the display.

## **9. Features**

### **Light Source**

- Lamp: TUV 36T5 HO 4P SE UNP/32 (PHILIPS)
- Extremely long Life: up to 9,000 H

### **Features**

- Audio feedback
- Visual indicator lights
- Fan speed settings
- Infrared remote control
- Control APP with WIFI

### **Product Type**

Commercial Air Purifier

### **Weight**

Net weight: 28.5 kg

## **10. Cleaning and Maintenance**

1. To ensure the device remains in good condition and does not fail prematurely, regular maintenance, cleaning and checks are required.
2. For cleaning of the device, please use a lint-free cloth.
3. To avoid damage to the device, never use detergent or solvents.
4. Never spray insecticide towards the device, it can discolor or damaged.
5. Should you need any spare parts, please order genuine parts from your local dealer.

## 11. Recycling

To protect the environment and human health, do not throw away the product with the normal household waste at the end of its life, hand it to your local collection point for recycling. Follow local rules for the separate collection of electrical and electronic products.

## 12. Service

For all service needs, please contact your local authorized dealer or GOLDENSEA customer service. Our contact details are:

Email: [support@goldenseauv.com](mailto:support@goldenseauv.com)

Tel: +86 20 3996 6388

Address: No.109 Haiyong Road, Shiji Town, Panyu Zone, Guangzhou, China. 511450

*Errors and omissions for all information given in this user manual are expected.  
All information is subject to change without prior notice.*



GOLDENSEAUM